

Form-on smartPROP 20 sF2

Criteria	smartPROP 20 sF2	
Type	300	350
Minimum length (cm)	172	197
Maximum length (cm)	300	350
Weight (kg)	10.7	13.3
Tube wall thickness (mm)	2.25	
Diameter outer tube (mm)	58.8	63.0
Diameter inner tube (mm)	46.8	51.0
Head-, base-plate thickness	5 mm (100x100 mm)	1
Material of the nut	cast steel	2
Thread pitch in grade	4°	3
Galvanization	strip-galvanized	
Drop-out latch	yes	4
Crush guard (min. 10 cm)	yes	5
Packaging units in pieces	48	
Load capacity	20 kN to Safety factor 2	

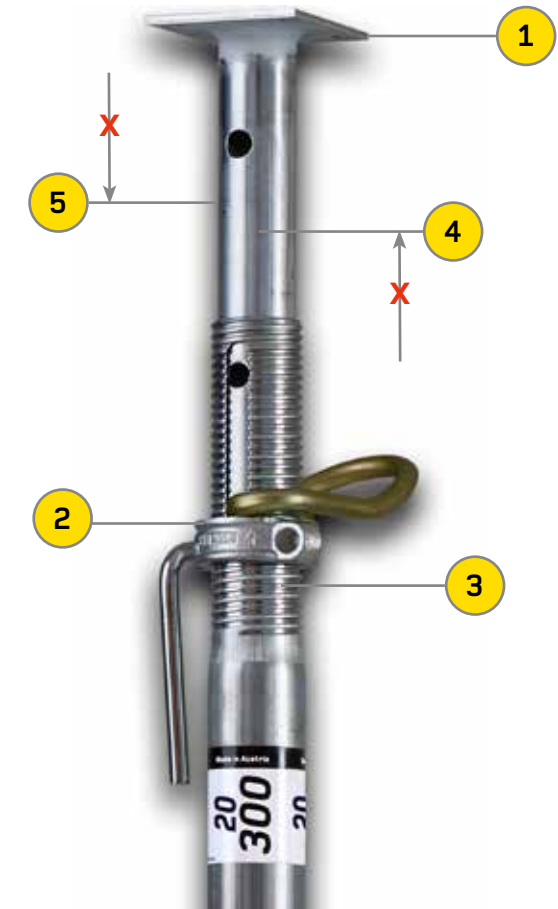

Form-on smartPROPplus 20

Criteria	smartPROPplus 20				
Type	250	300	350	400	550
Minimum length (cm)	148	173	198	223	298
Maximum length (cm)	250	300	350	400	550
Weight (kg)	11.5	13.8	16.8	21.0	32.5
Tube wall thickness (mm)	2.6				
Diameter outer tube (mm)	60.8	66.0	71.0	76.5	89.2
Diameter inner tube (mm)	48.8	54.0	59.0	64.5	77.3
Head-, base-plate thickness	8 mm				1
Material of the nut	forged steel				2
Thread pitch in grade	6 °				3
Galvanization	strip-galvanized				
Drop-out latch	yes				4
Crush guard (min. 10 cm)	yes				5
Packaging units in pieces	42	42	42	35	30
Load capacity	B/D	B/D	C/D	C/D	C/D

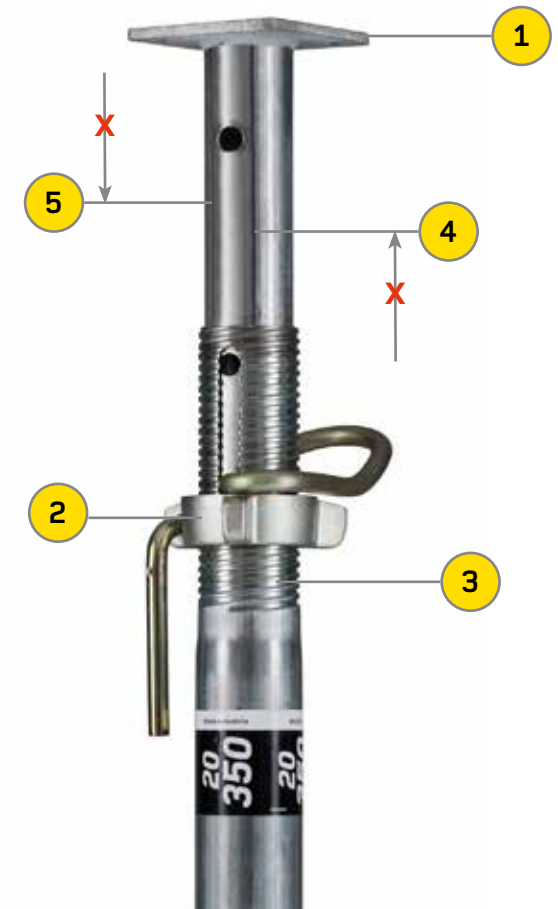



TIP: Increased loading capacity, due to rotated application of the prop

Normal application

smartPROPlus 20 300 = EN1065 Class B/D

Length (m)	300
3.0	20.3
2.9	22.0
2.8	23.7
2.7	25.0
2.6	25.9
2.5	26.9
2.4	27.7
2.3	28.6
2.2	29.6
2.1	31.0
2.0	32.3
1.9	33.9
1.8	35.5
1.7	
1.6	
1.5	



Loading capacity smartPROPlus 20 300 in kN

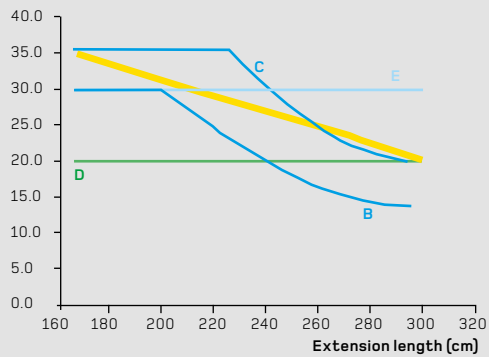

Rotated application

smartPROPlus 20 300 = EN1065 Class C/D

Length (m)	300
3.0	24.3
2.9	26.9
2.8	29.4
2.7	31.8
2.6	34.2
2.5	
2.4	
2.3	
2.2	36.7
2.1	
2.0	
1.9	
1.8	
1.7	
1.6	
1.5	



Loading capacity smartPROPlus 20 300 in kN

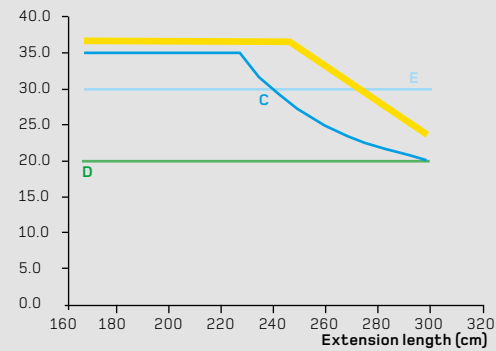

Form-on smartPROPplus 30

Criteria	smartPROPplus 30	
Type	300	350
Minimum length (cm)	173	198
Maximum length (cm)	300	350
Weight (kg)	16.3	20.3
Tube wall thickness (mm)	inner tube: 3.0 & outer tube: 2.6	
Diameter outer tube (mm)	71.0	76.5
Diameter inner tube (mm)	59.0	64.5
Head-, base-plate thickness	8 mm	
Material of the nut	forged steel	
Thread pitch in grade	6°	
Galvanization	strip-galvanized	
Drop-out latch	yes	
Crush guard (min. 10 cm)	yes	
Packaging units in pieces	42	35
Load capacity	C/E	C/E

